

MOUNTING PROCEDURE

1. PARTS COMPLY WITH AMP SOLDERABILITY SPEC. 109-11-3.
2. RECOMMEND EXPOSURE TO SOLDER WAVE (490°F) NOT TO EXCEED 5 SECONDS.

REV.	DATE	APPROVED	DESCRIPTION
1	7/18/83	TDJ/9m	RELEASED NEW DRAWING, TT 83-44
2	7/18/83	BD/RS	CHANGED PICTORIALITY, M-7389
3	7/18/83		RESTORED

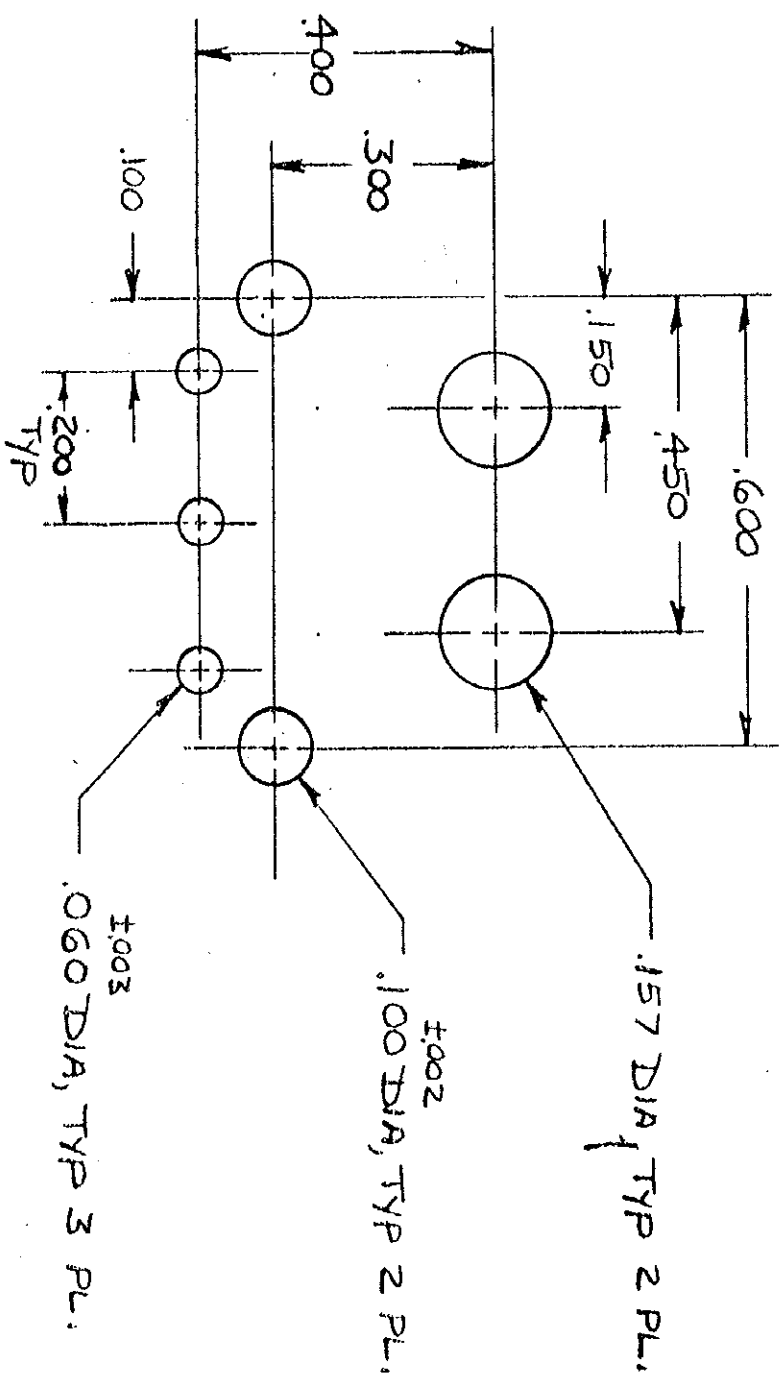

RECOMMENDED LAYOUT FOR .062 THICK P.C. BOARD  
TOL: ±.005

NO.	DESCRIPTION	MATERIAL & FINISH	ITEM NO.	PART NO.
3	CONTACT	PH BRZ, PRE-TIN	2	643488-1
1	HOUSING	NYLON, 94V-0, NATURAL	1	

UNLESS OTHERWISE SPECIFIED DIMENSIONS ARE IN INCHES. TOLERANCES ON: DECIMALS ±.015 ANGLES		CONTRACT NO. 4-11-83		NAME: AMP INCORPORATED, Harrisburg, Pa. 17105	
MATERIAL: SEE TABLE		DR: D.A. SALTZER	CHK: H. E. TRAVIS	PC HEADER ASSEMBLY, RIGHT ANGLE MOUNT, 3 CIRCUIT, COMMERCIAL MATE-N-LOK	
FINISH: SEE TABLE		APPD: H. E. TRAVIS	DATE: 4/18/83	SIZE: C	FSCM NO: 00779
		DSGN APPD:	OTHER APPD:	DRAWING NO: 643488	SCALE: 4:1