

THIS DRAWING IS UNPUBLISHED. RELEASED FOR PUBLICATION
 BY AMP INCORPORATED. ALL RIGHTS RESERVED.

Loc		DIST		REVISIONS			
P	LTR	DESCRIPTION		DATE	DWN	APVD	
AF	50	B		REDRAWN AND UPDATED 0710-0302-96	26JUL96	MF	NN

1 CONTINUOUS STRIP ON REELS WITH TERMINALS LOCATED ON 5.59±0.08 [.220±.003] CENTERS.
 2 SLOT TERMINATES A SINGLE MAGNET WIRE ONLY. COPPER RANGE: 0.57-0.81mm [#23-#20] AWG.

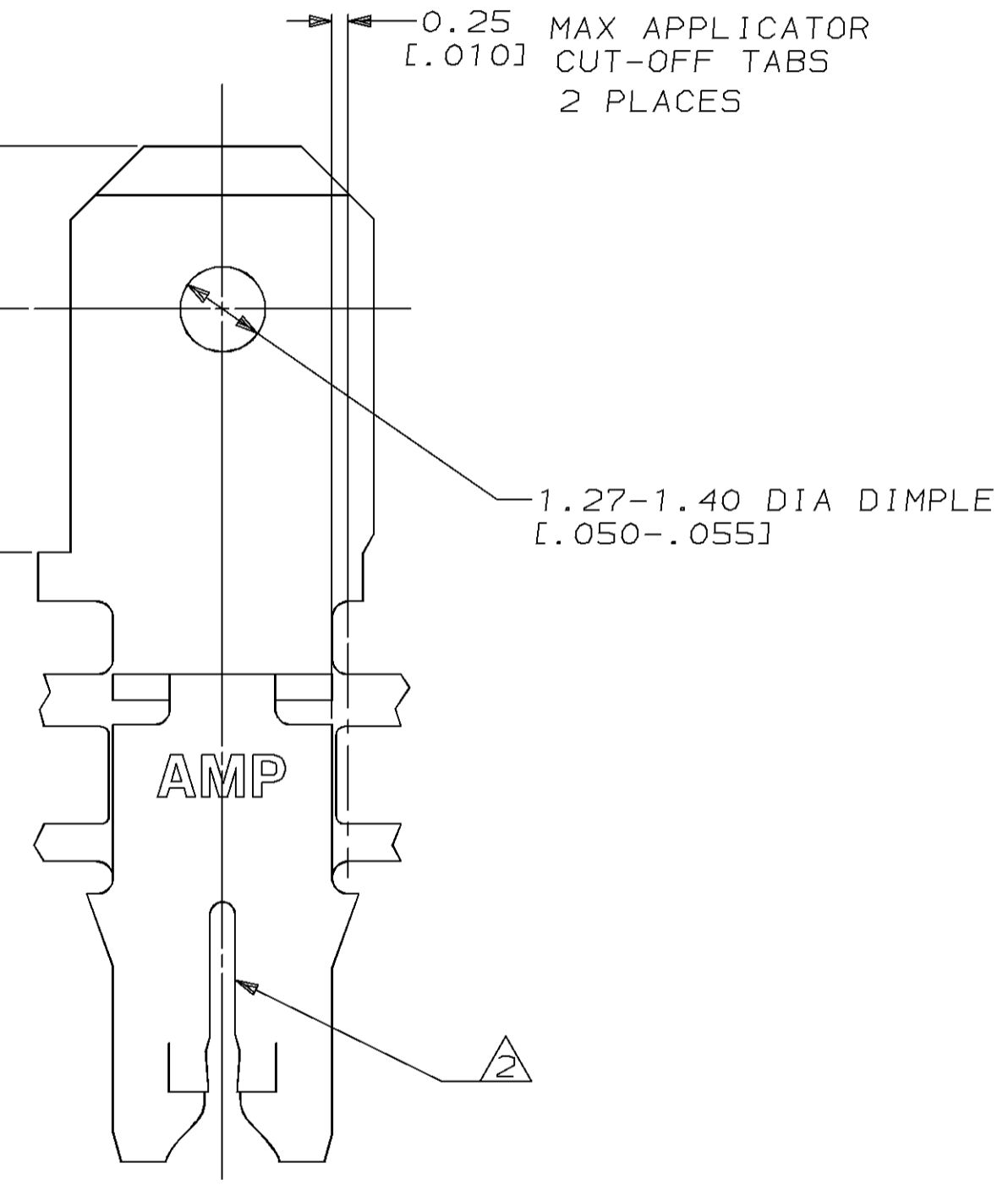
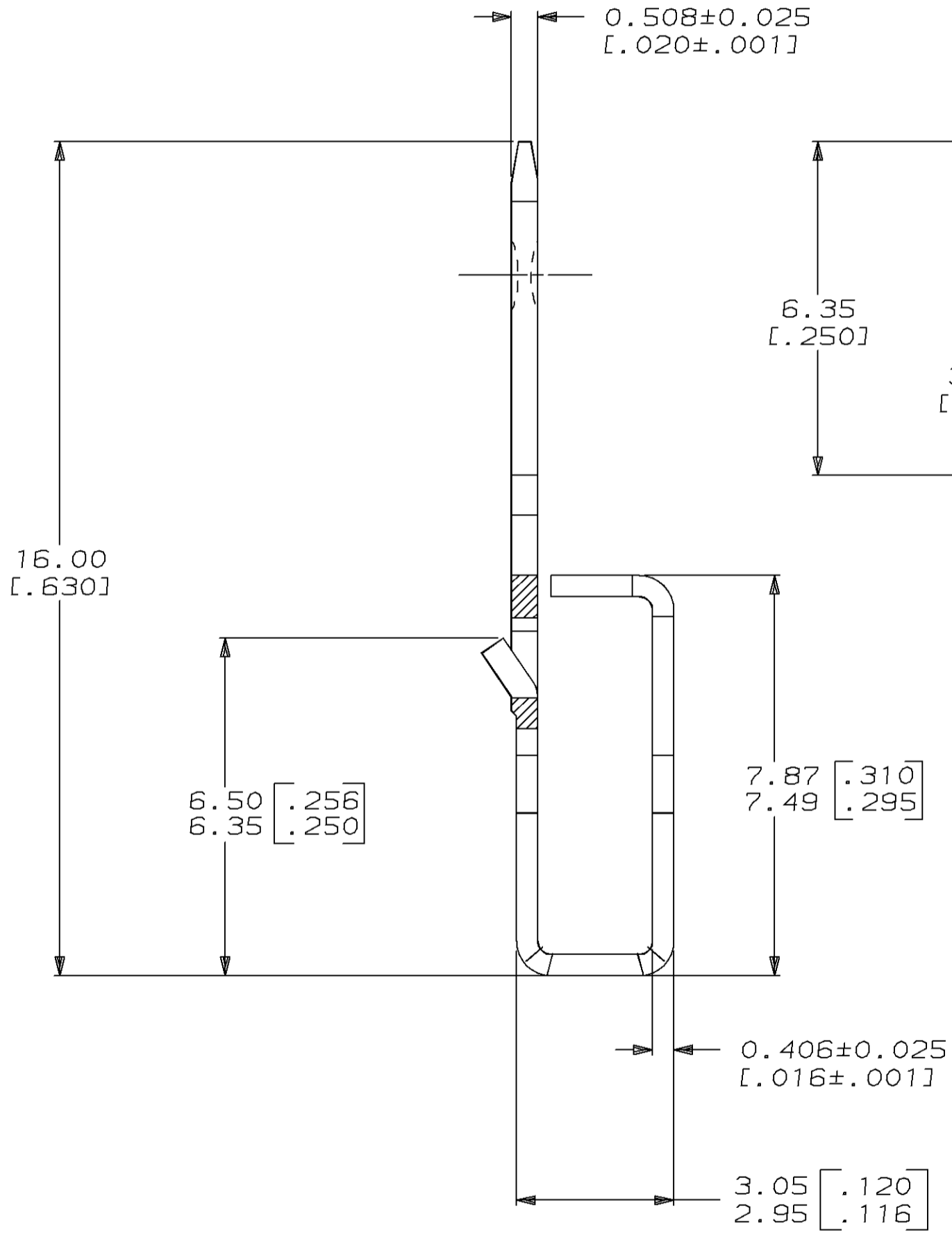
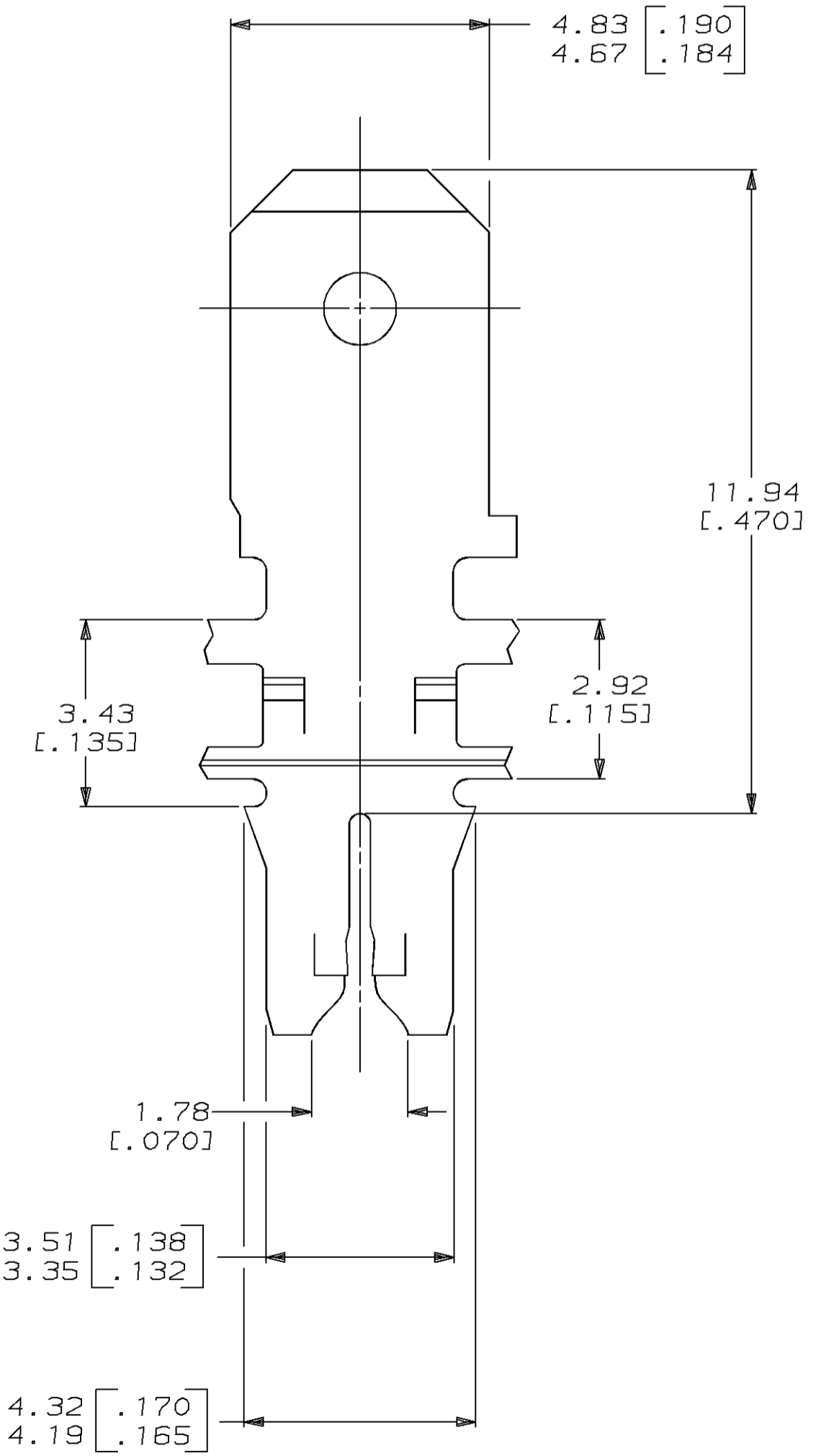
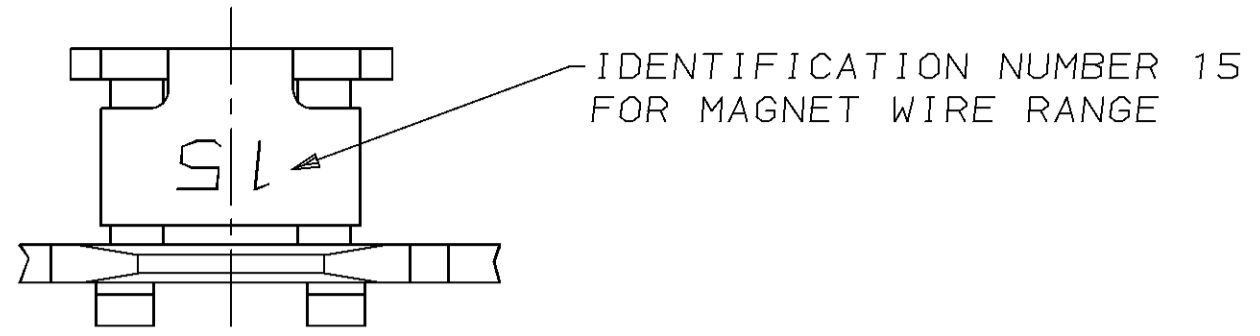

63340-1
 PART NUMBER

THIS DRAWING IS A CONTROLLED DOCUMENT.		DWN MICHAEL S. FEHER 26JUL96	AMP Incorporated Harrisburg, PA 17105-3608	
DIMENSIONS: mm [INCHES]		CHK RICHARD GRZYBOWSKI 29JUL96	NAME TERMINAL, TAB, 4.75 [.187] FASTON, TM MAG-MATE TM	
TOLERANCES UNLESS OTHERWISE SPECIFIED:		APVD NELSON E. NEFF 29JUL96	PRODUCT SPEC 108-2012	SIZE A2
0 PLC ±- 1 PLC ±- 2 PLC ±0.25 [.010] 3 PLC ±- 4 PLC ±- ANGLES ±-		APPLICATION SPEC 114-2067	CAGE CODE 00779	DRAWING NO C=63340
MATERIAL 4M PRE-MILLED BRASS	FINISH 0.002032 [.000080] MIN TIN PER MIL-T-10727	WEIGHT -	SCALE 10:1	SHEET 1 OF 1
CUSTOMER DRAWING			REV B	